



CREHS Inc

DIGITAL SOLUTIONS
IN HEALTH SERVICES

Centre for Rehabilitation and Health Services

<https://crehsinc.com/>

NAME : DR. GODFREY ONWUBOLU, PhD, FBCS, CEng, PEng

**TOPIC : PANEL/FIRESIDE VIRTUAL CHAT- COLLABORATION WITH
MEDICAL AM & DDM COMMITTEES APRIL 1, 2021**

1. Introduction

- ▶ CREHS Inc. provides digital solutions in healthcare (Medical, Dental and O&P) services through AM.
- ▶ Owns a digital dentistry laboratory having 21st Century digital technologies mainly from Dentsply–Sirona: inEos X5 lab scanner; inLab SW; and SprintRay 3D printer. Company has chosen Medical AM field because it is the technology of today and tomorrow.

Medical programs, initiatives at CREHS:

- ▶ Providing orthodontic devices to local dental clinics
- ▶ Collaborative provision of medical solutions to practitioners at disparate locations (overseas); this is a new dimension in medical industry

2. Rapid Medical Response Story

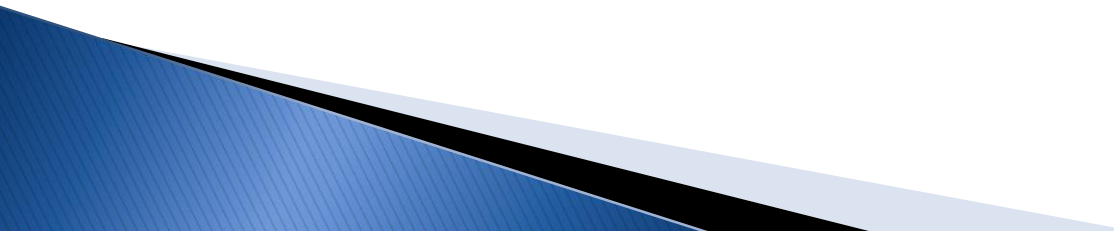
- ▶ **Timely Networking (Rapid Medical Response)**
 - ▶ **Situational Analysis**
 - ▶ **Our goal**
 - ▶ **Education**
 - ▶ **Editable Designs**
 - ▶ **Personal protective equipment (PPE): Face Masks and Face Shields**
 - ▶ **Venturi Valve for Ventilator Systems**
- 

3. Timely Networking (Rapid Medical Response)

- ▶ As soon as there was lockdown, the first step taken was to network with a number of professionals, institutions and companies to provide Additive Manufacturing/3D printing solutions to the pandemic outbreak.
- ▶ March 17, 2020: Lockdown in Ontario was declared
- ▶ March 28, 2020: As early as this date, we sent out a proposal to a number of organizations /individuals for a Team to be formed to 3D-print Medical Devices for COVID-19

3. Timely Networking (Rapid Medical Response)

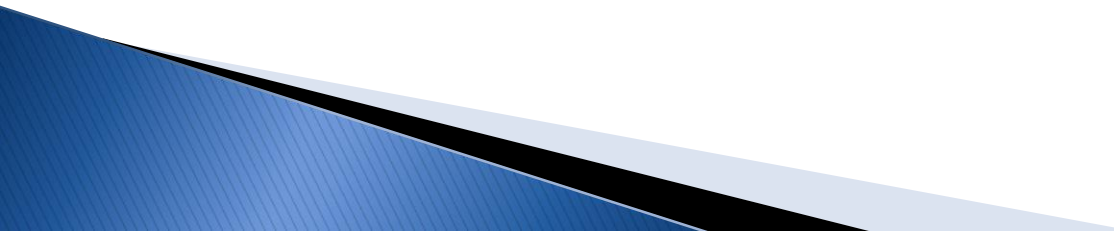
- ▶ This campaign phase showed various results:
 - ▶ –some individuals or organizations were working on their own
 - ▶ –some individuals or organizations were willing for participants to join their team
 - ▶ –some individuals or organizations were providing solutions to help victims of the pandemic
- 

4. Situational Analysis

- ▶ We decided to focus on Face Masks, Face Shields, and Ventilation Valves. Initial search showed that most designs were published to the public as STEP or 3D OBJECT files. These designs could be 3D printed, but they only satisfied specific needs, hence they were limited in practice. A lot of these designs were available in Grab CAD website.

5. Our goal

- ▶ Our goal was to provide a database of editable designs so that these could be modified to meet specific practical needs. This approach was found to be more useful for people to respond to the varying pandemic situations. We aimed at providing designs in SOLIDWORKS files so that these designs could be modified and then 3D printed to meet immediate needs on the field.

6. Education

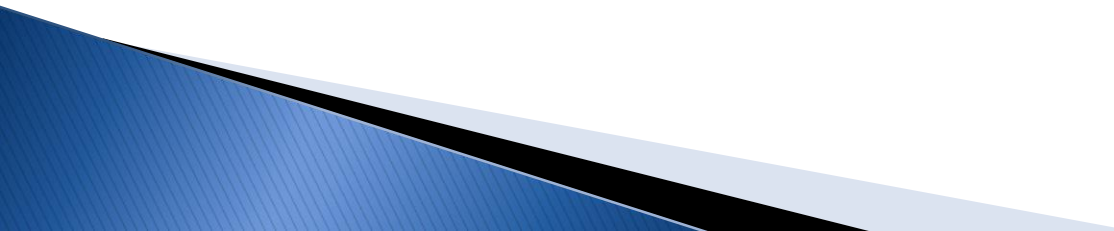
- ▶ 20 engineering graduate students were engaged during the March to May 2019 lockdown, focusing on basic personal protective equipment (PPE)
 - ▶ 17 engineering graduate students are still currently engaged: focusing on ventilators
 - ▶ Several others engaged to provide solutions
- 

7. Editable Designs

- ▶ Database of editable designs was the goal so that we can modify designs to meet specific needs. This will be more useful to people to respond to the pandemic situation.

8. Personal protective equipment (PPE)

- ▶ **FACE MASKS:**
- ▶ –Copper3D–Antimicrobial–Mask–1
- ▶ –3D printable face shield: Filtertraeger
- ▶ –Lafactoria3D: use only with P3 particle filters
- ▶ –The Self–Assembly Filter for Emergencies (S.A.F.E.) Cartridge System of Medical University of South Carolina: STL
- ▶ –Copper3D – Chile: STL

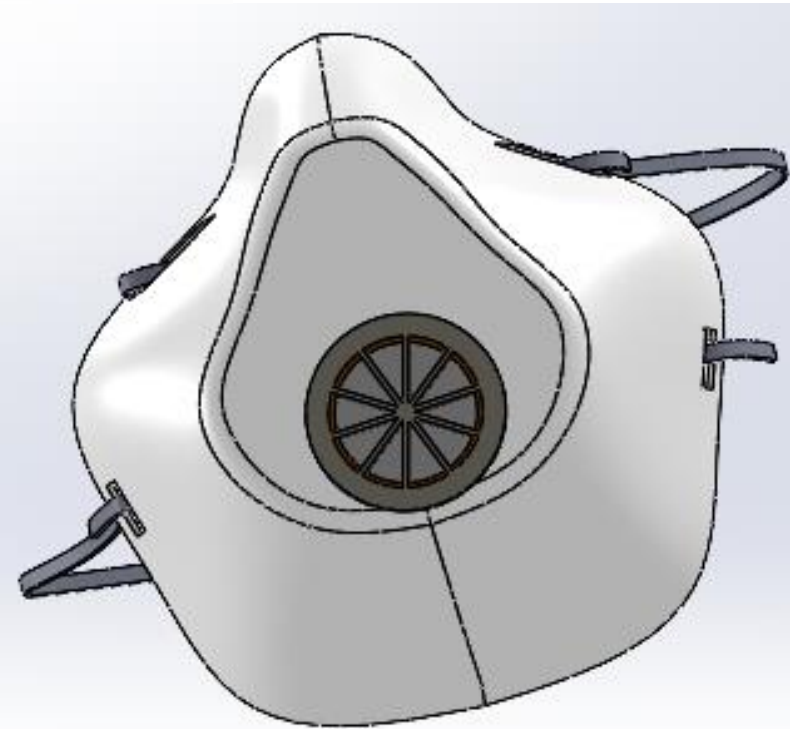
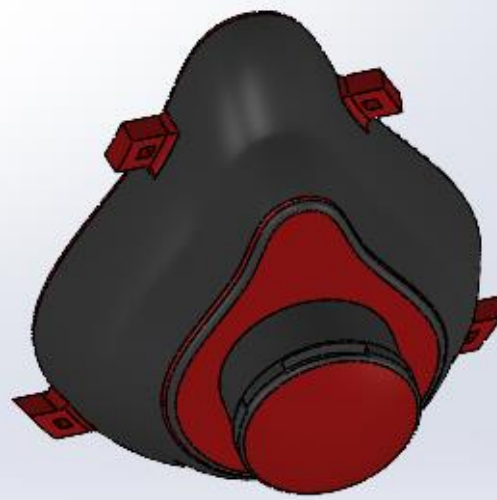
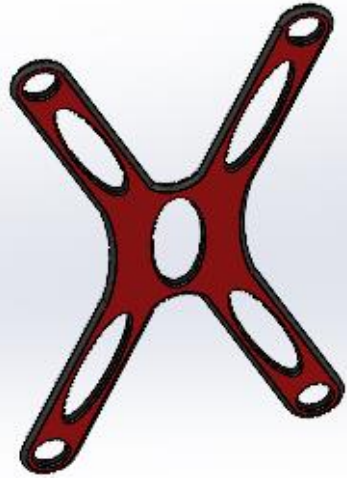

Editable Face Masks

8. Personal protective equipment (PPE)

- ▶ **FACE SHIELDS:**
- ▶ –faceshield–master
- ▶ –MyPalate Aegis Face Shield
- ▶ –NanoHack: STL digital files
- ▶ –Prusa 3D printable face shield: STL
- ▶ –Mascara decathlon
- ▶ –Tangible_Choksi_3_FaceShield

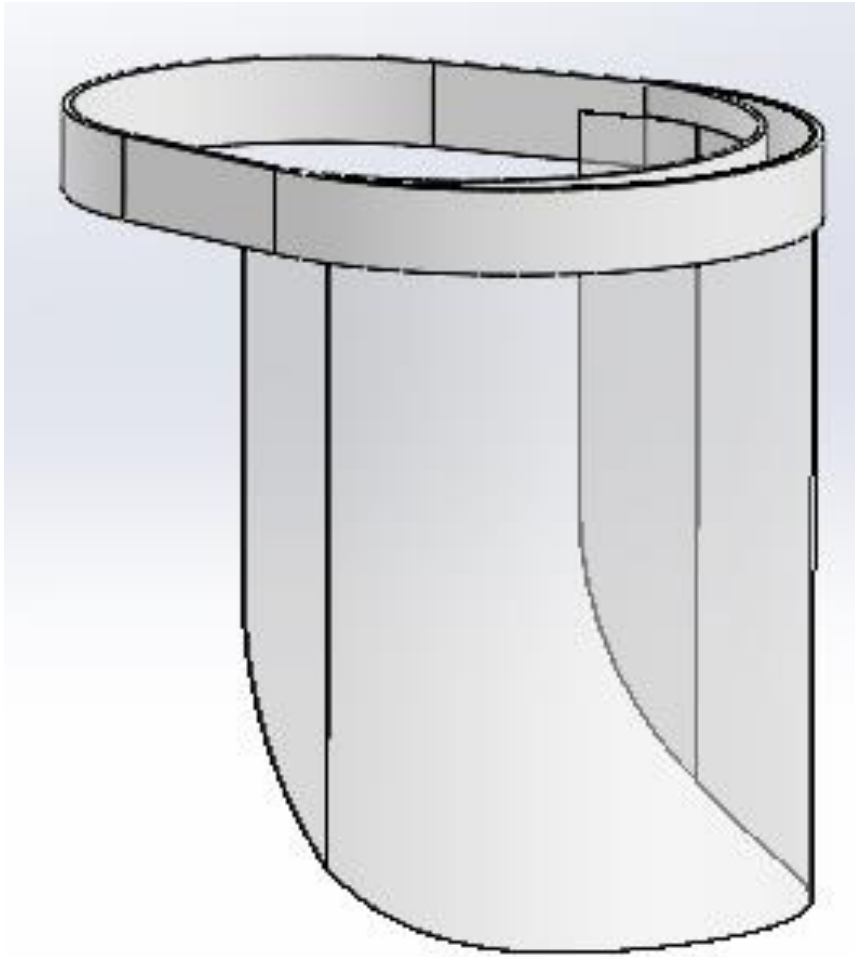

Editable Face Shield

9. Venturi Valve for Ventilator Systems

- ▶ We examined more sophisticated Respirators and Ventilators. Most venturi valve solutions are in STEP or STL formats.
- ▶ –Charlotte Valve by Isinnova: STEP
- ▶ –Valve regulator–STL

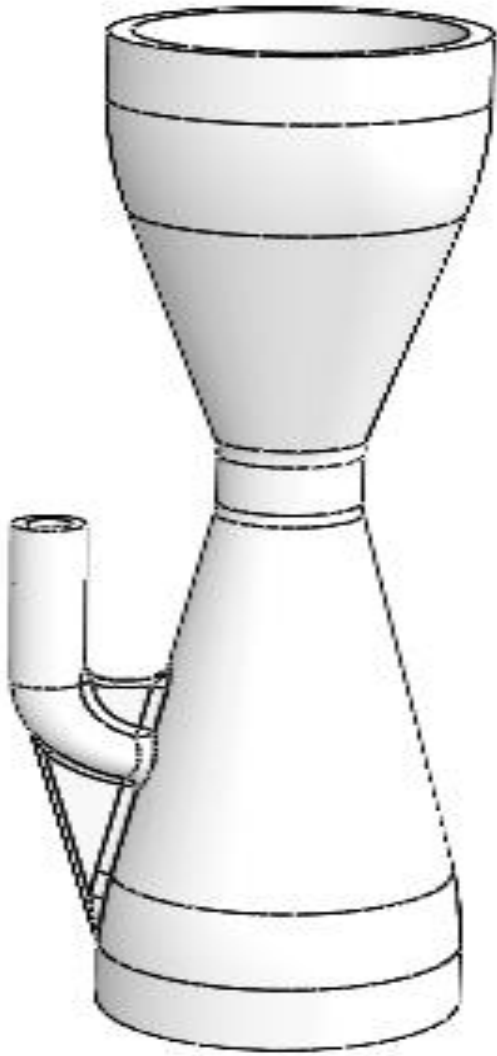

Editable Venturi Valve

10. Rapid Medical Response Story

- ▶ Additive Manufacturing/3 D printing was useful in addressing medical supply challenges and the crisis response. It's application was vital to slowing the spread and mitigating the many adverse consequences of the virus – leading to saving many lives.
- ▶ But how effective are most of the solutions? These questions have to be answered.

Finishing!!!

- ▶ Thank You!